

AMEREC "DESIGNER" SERIES SAUNA HEATERS MODELS 4.5B, 6.0B, 8.0B (With built-in control)

Read all instructions carefully before installation. Please leave all instructions and warranty with the owner.

WARNING

Prolonged exposure to elevated temperatures is capable of inducing hyperthermia. Hyperthermia occurs when the internal temperature of the body reaches several degrees above the normal body temperature of 98.6°F. The symptoms of hyperthermia include an increase in the normal temperature of the body, dizziness, lethargy, drowsiness, and fainting. The effects of the hyperthermia include failure to perceive heat, failure to recognize the need to exit the room, unawareness of impending hazard, fetal damage in pregnant women, physical inability to exit the room and unconsciousness.

WARNING

The use of alcohol, drugs, or medication is capable of greatly increasing the risk of fatal hyperthermia.

SECTION 1: GENERAL INFORMATION

These heaters are UL approved for permanent installations and electrical connections. Built with splash proof construction, the conducting parts are protected against water. All wiring must be performed in accordance with local codes. See Diagram 5 for wire and room size requirements.

These heaters are wall mounted, 16 W x 11 D x 23 H, with built in controls.

WARNING

Do not take a sauna if using alcohol, drugs or medications.

Pregnant women or persons with poor health should consult their physician before using any sauna.

Caution fire hazard: Do not use the sauna room for drying clothes, bathing suits, etc. Do not hang towels above heater or place any object other than the rocks supplied on the heater. If any darkening of the wall around the heater is noticed discontinue sauna use immediately.

Inspect sauna regularly for required maintenance to heater, control and benches. Replace wood surfaces which show any signs of deterioration.

The heater gets extremely hot during operation and should not be touched or burns may result.

Minors should be adequately supervised whenever near a hot or warming sauna.

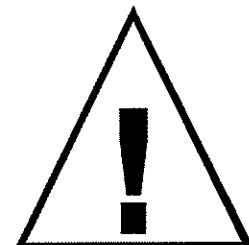
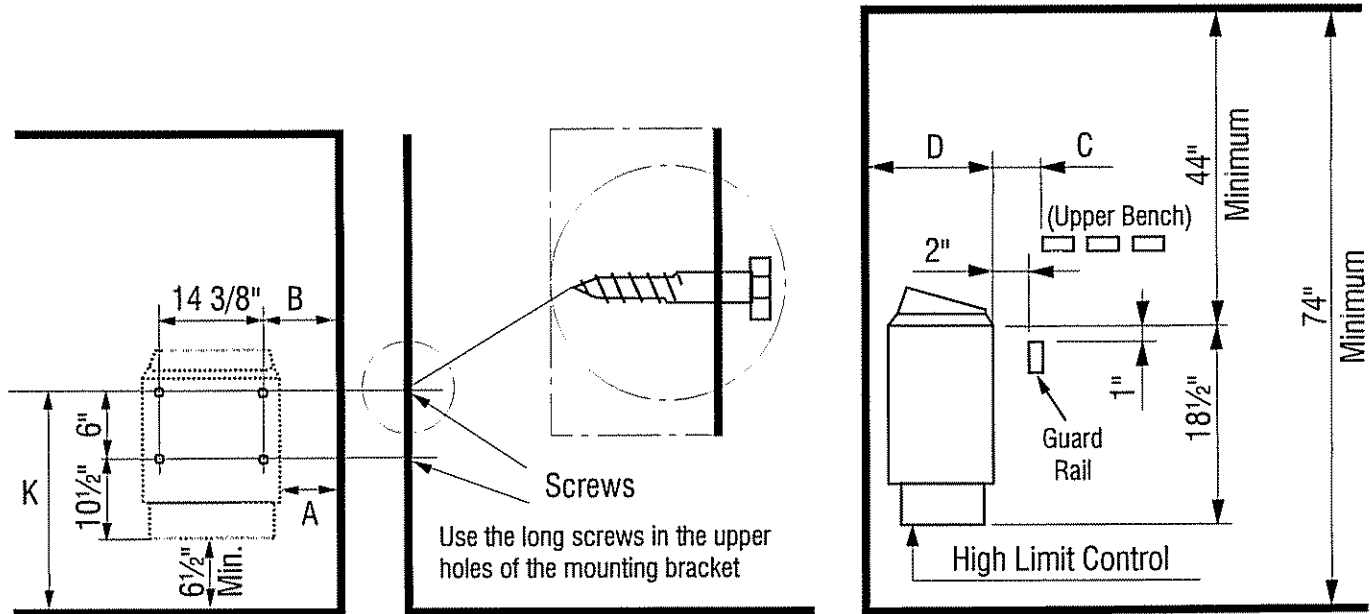

DIAGRAM 1

MOUNTING BRACKET LOCATION AND TO MINIMUM DISTANCE TO COMBUSTIBLE MATERIAL



Recheck your distances from the heater to combustible materials to be sure you have the proper minimum distances.

HEATER	MINIMUM				
	"A" DISTANCE	"B" DISTANCE	"C" DISTANCE	"D" DISTANCE	"K" DISTANCE
DESIGNER 4.5B	3.0"	3 5/8"	4.0"	10 3/4"	23"
DESIGNER 6.0B	4.0"	4 5/8"	5.0"	10 3/4"	23"
DESIGNER 8.0B	5.0"	5 5/8"	6.0"	11 1/2"	23"

! OBSERVING MINIMUM DISTANCES IS REQUIRED TO AVOID FIRE HAZARD

DIAGRAM 2

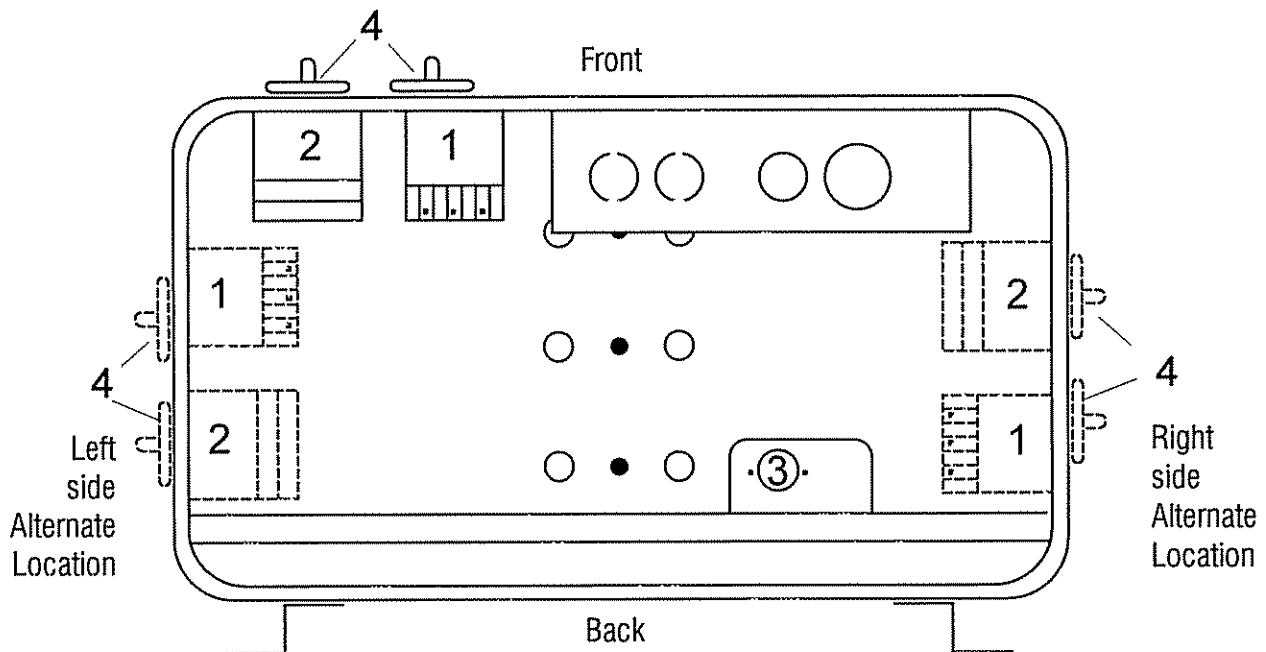

- 1. Timer
- 2. Thermostat
- 3. High limit control (Reset)
- 4. Knobs for the thermostat and the timer.

**SECTION 2: MOUNTING OF SAUNA HEATER**

For ease of operation, the heater controls may be mounted on the front or either side. If the controls are relocated, this should be done before mounting the heater to the wall.

MOVING THE CONTROLS Lay the heater on its back: remove the control knobs by pulling them straight off (See Item 1 on Diagram 3); unsnap the plastic label plates from the left and right sides of the electrical enclosure and remove the screws from the left and right sides of the electrical box (See Item 2 on Diagram 3) and from the bottom cover of the box. Remove the painted trim piece from the front of the box. Remove the bottom cover by sliding it towards the back of the heater.

Remove the screws mounting the controls then carefully move the controls to their new position. Reassemble in the reverse order using the original hardware. Ensure that no wires are pulled loose, pinched, kinked, pulled tight or otherwise damaged. Use the plastic label plates to cover the unused control mounting positions.

HANGING THE HEATER Using the template provided, drill four 9/64" holes to fasten the heater to the wall. Install two 1/4" x 1 1/2" hex head lag screws (supplied with the heater) into the upper two holes. Tighten these screws until their heads are about 1/8" from the wall surface. The screws must be threaded through the wall into a framing member or backing board to support the heater weight. Hang the heater on the two upper screws.

Locate the two 1/4" x 1" hex head lag screws (supplied with the heater) then install them into the two lower mounting holes. Tighten to lock the heater in place.

See Diagram 1 & 2 for the heater location details and the necessary clearances to combustible materials.

SECTION 3: PLACING OF ROCKS (SEE DIAGRAM #10)

The rocks supplied with the heater have been chosen to provide the best heater performance. Use of any other type of rock may void the heaters warranty. Never operate the heater without rocks in place!

Rinse the rocks with water before placing in the heater. Carefully place the rocks loosely so that the air can circulate through the heater. Packing the rocks too tightly may cause the heater high limit switch to trip. The rocks must fully cover the heating elements. Attach the guard with the screws provided.

WARNING

Fire sprinkler systems used inside any sauna room should be properly rated for sauna room temperatures.

Do not pour chlorinated pool or spa water on heater. Excessive water use on heater may cause damage and void warranty.

Electric Shock Hazard - High voltage exists within this equipment. There are no user serviceable parts in this equipment. All installation and service to this equipment should be performed by qualified licensed personnel in accordance with local and national codes.

Do not construct sauna room so as to restrict air flow through the bottom of the heater.

Rock preheat required. Although the rocks are specially selected for use with this sauna heater, concealed moisture could cause the rocks to crack and project fragments causing potential injury when the rocks are heated. The rocks must be preheated on the sauna heater for two hours at maximum temperature with no one in the sauna room.

Packing the rocks too tightly may cause the heater high limit switch to trip.

DIAGRAM 3

MOVING THE CONTROLS

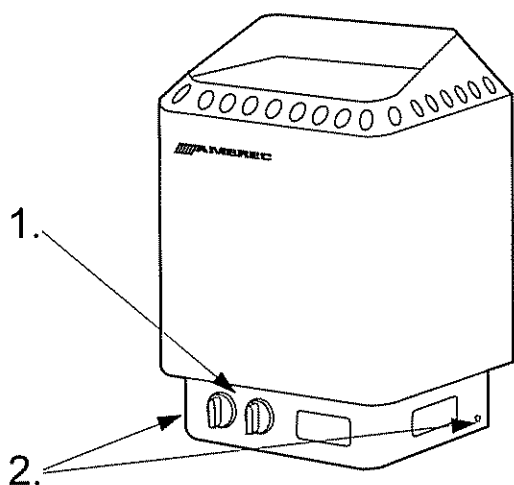

1. Remove knobs.
2. Remove screws on side of heater.

DIAGRAM 4

ONE HOUR OPERATING ZONE FOR 9 HOUR DELAY TIMER
 This area from "OFF" to "ON" is the operating zone. This is the only time the heater is on.

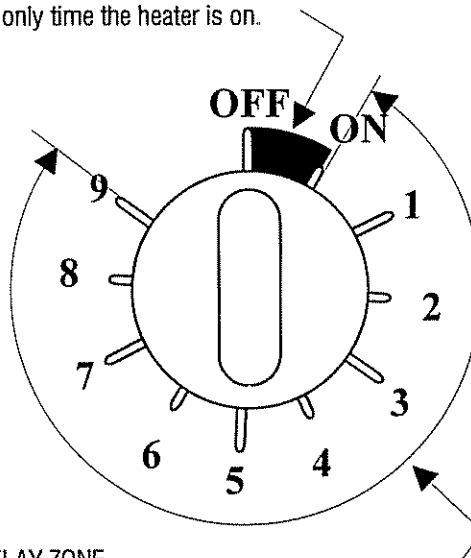

DELAY ZONE
 This area from "9" to "ON" is the delay zone, meaning the heater can be programmed to come on up to nine hours later. The heater will not operate in this area.

DIAGRAM 5

HEATER MODEL / Product Number	KW	MINIMUM ROOM			MAXIMUM ROOM		PHASE	VAC	AMPS	WIRE SIZE
		Floor Area	Ceiling Height	Volume Cu.Ft.	Ceiling Height	Volume Cu.Ft.				
DESIGNER 4.5B (-3 = 3 Phase) 1712-45-17	4.5	16 sq. ft.	74"	100	96"	210	1	208	21.6	10-2 W/G
							1	240	18.8	10-2 W/G
							3	208	12.5	12-3 W/G
							3	240	10.8	12-3 W/G
DESIGNER 6.0B (-3 = 3 Phase) 1712-60-17	6	28 sq. ft.	74"	175	96"	310	1	208	28.8	8-2 W/G
							1	240	25	10-2 W/G
							3	208	16.7	12-3 W/G
							3	240	14.4	12-3 W/G
DESIGNER 8.0B (-3 = 3 Phase) 1712-80-17	8	40 sq. ft.	74"	250	96"	425	1	208	38.5	8-2 W/G
							1	240	33.3	8-2 W/G
							3	208	22.2	10-3 W/G
							3	240	19.2	10-3 W/G

**SECTION 4: ELECTRICAL HOOK-UP**

Electrical installation must be made by a licensed electrician in accordance with the National Electrical Code and local regulations.

Remove the control knobs by pulling them straight off; unsnap the two plastic label plates from the electrical enclosure and remove the screws from the left and right sides of the electrical box. Remove the painted trim piece from the front of the box. Route the feed wires through the holes provided in the bottom of the heater and connect the wires to the terminal block. To determine the correct wire size, refer to Diagram 5. Use copper supply wire only, suitable for minimum 90 degrees C. The heater must be grounded! See Diagram 6 for proper connections.

SECTION 5: HEATER SCREEN (GUARD RAIL)

Install a wooden heater guard to prevent the sauna bather from accidentally touching the sauna heater. Install the heater guard rail with the height clearances and dimensions shown in Diagram 8.

SECTION 6: OPERATION

The heater is provided with a thermostat to adjust the sauna bath temperature and a timer to control when the bath starts and stops. For health and fire safety, never attempt to alter or bypass the timer or thermostat. If the sauna is to be used without an automatic timer provided, an attendant must be present at all times.

SETTING THE TEMPERATURE The temperature can be adjusted by turning the thermostat knob. To raise the temperature, turn the knob clockwise; to lower the temperature, turn the knob counter-clockwise.

SETTING THE TIME If you want the heater to begin heating immediately, turn the dial clockwise past the first marked section labeled "off to 1" (See Diagram 4), then turn the dial back (counter-clockwise) until you feel it "click", near the on position, into the one hour operating zone.

The heater has a "9 plus 1" timer, which means you can set the heater to begin heating after a delay of up to 9 hours.

If you set the timer dial in the "1 to 9" zone, the heater will automatically turn on after the selected delay time has elapsed.

WARNING

Do not locate benches over heater. Minimum clearance of ceiling above heater 44".

Minimum clearance from heater to wooden surfaces (benches, side walls, heater fence etc.) 2 inches. Mounting brackets supplied. Provides proper clearance from wall behind heater.

Use only copper wire of the size and type indicated in the Heater Specification Chart and the temperature rating indicated on the heater junction box.

All heaters and controls must be grounded per NEC to prevent electrical shock in case of unit failure.

Electrical outlets or receptacle must not be installed in a sauna room.

A guardrail or fence is required around the heater to prevent burns from accidental contact.



DIAGRAM 6

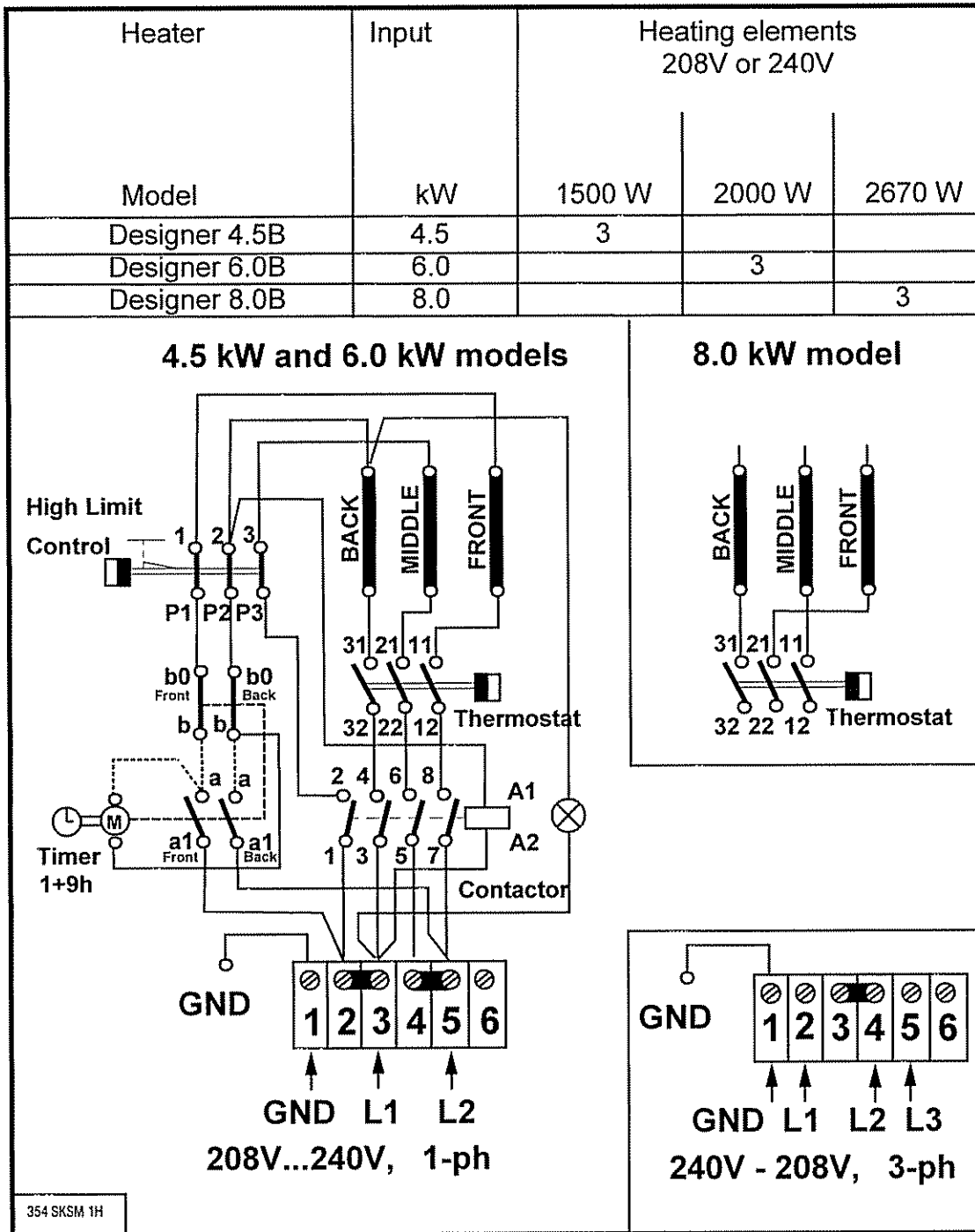

See Diagram 5 for supply connections copper wire size



SECTION 7: HIGH LIMIT CONTROL (RESET BUTTON)

The sauna heater has a built-in high limit control, which automatically turns off the heater if the temperature inside in the sauna room rises to an abnormally high level.

To restart the heater, let the heater cool and turn the timer down to zero (off), then push the reset button on the bottom of the heater, See Item 3 on Diagram 2. If the high limit continually shuts off the heater, contact a service representative at 1-800-331-0349.

SECTION 8: HOW TO TAKE A SAUNA

- When taking a sauna, allow time to relax completely.
- Remove clothing and jewelry...if required, wear a towel loosely.
- After 10 minutes or when perspiration begins, leave sauna and relax in dressing area...follow with a cool shower.
- Cooling time should equal time spent in sauna. Enter sauna room again and stay 5 or 10 minutes.
- Repeat the cycle 2 or 3 times; end with a brisk shower...rinse in cool water.
- Dress when completely dry and perspiration has stopped.
- Some sauna bathers enjoy the soothing effect of steam by splashing water on the heated sauna rocks. Use only one dipper full (approx. 1/2 cup) at a time and take care to keep clear of the steam as it rises off the rocks.
- Do not smoke, exercise or drink alcoholic beverages in the sauna room.
- Do not pour chlorinated pool or spa water on the heater or corrosion damage may result.



Shower



Sauna (10 - 15 min.)



Shower or swim



Rest (10 - 15 min.)

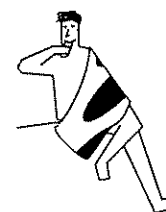

Relax with juice or water

You liked it?
Do it once again and
you will feel great.

DIAGRAM 7

TYPICAL PRE-CUT WALL CONSTRUCTION

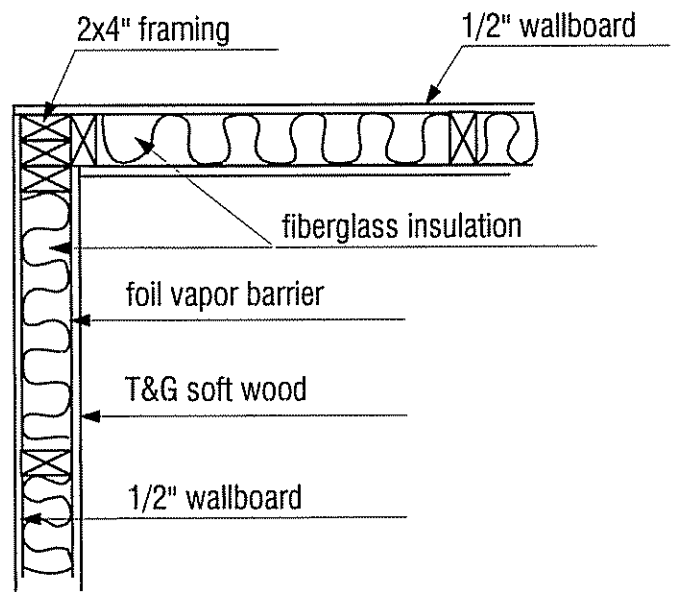

DIAGRAM 8

HEATER SCREEN (GUARD RAIL)

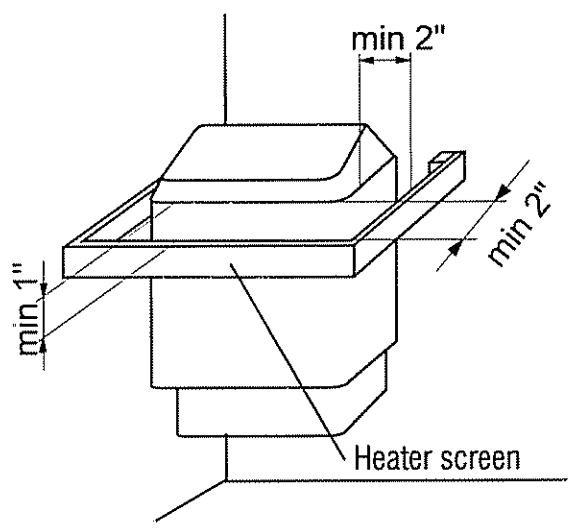

DIAGRAM 9

VENTILATION

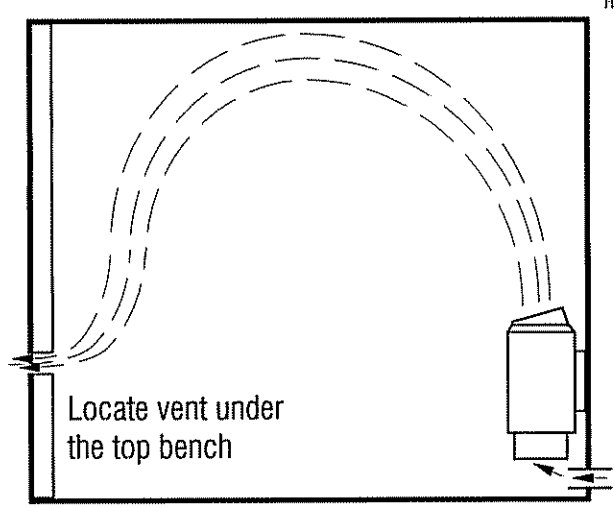
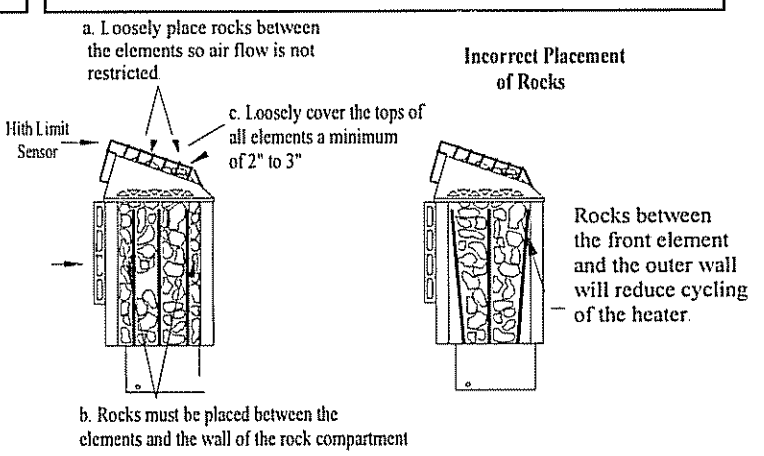

DIAGRAM 10



1. Put smaller rocks in first around the outer perimeter of the heating chamber.
2. Completely fill all four sections (front, 2 center sections between elements, and back).
3. In the outer sections, use smaller rocks placed more tightly (see note b).
4. Place rocks loosely in the center 2 sections (see note a).
5. Be sure rocks completely cover the elements (see note c).
6. Loosely cover the tops of all elements a minimum of 2" to 3".



SECTION 9: WARNING PLACARDS

Two metal placards are included in the Installation Instruction Envelope packaged with every Sauna Heater. The CAUTION placard must be attached to the interior wall of the sauna room directly above the heater where it is visible to the bather. The WARNING placard must be attached to the door of the sauna room.

SECTION 10: ROOM CONSTRUCTION

For safety and reliability, the following rules must be addressed.

- No permanent locking or latch system is to be used on the sauna door.
- Acceptable door fittings are: magnetic catches, friction catches, spring or gravity loaded closures. The door must always open outwards.
- No shower may be installed in a sauna room.
- No electrical receptacle shall be installed inside the sauna room.
- The enclosed WARNING: Reduce the risk of overheating ... warning plate must be mounted on or alongside the door outside the sauna room at about eye level.
- The enclosed CAUTION: Reduce the risk of fire ... caution plate must be mounted on the interior wall above the heater.
- The heater should not be operated without its container properly filled with rocks and the rock guard in place.
- If an intercom speaker is installed, it should be away from the heater and as close to the floor as possible.
- If a room light is installed, it should be a surface mounted bracket type. Wall mounted lights should be about 70" above the floor. Ceiling mounted lights should be of an approved type with a junction box that is remote to the fixture itself. Use only a fixture that uses A.F. or fixture type internal wiring. A 60 watt bulb should provide sufficient lighting.
- Fire sprinkler systems installed inside any sauna room should be properly rated for sauna room temperatures.
- Always mount the heater according to these installation instructions.

WARNING

The "CAUTION" and "WARNING" placards must be mounted in accordance with Section 9.



WARNING

REDUCE THE RISK OF OVERHEATING

- * Exit immediately if uncomfortable, dizzy, or sleepy. Staying too long in a sauna is capable of causing overheating.
- * Supervise children at all times.
- * Check with a doctor before use if pregnant, in poor health, or under medical care.
- * Breathing heated air in conjunction with consumption of alcohol, drugs, or medication is capable of causing unconsciousness.



CAUTION

REDUCE THE RISK OF FIRE

Do Not Place Combustible Material On The Heater At Any Time.

For safety purpose sauna door must open out and not lock.

Never use a wood stain, seal or preservative on the inside of your sauna room.

Light fixtures get very hot during operation. Locate light fixture where it will not be a burn hazard.

SECTION 11: VENTILATION

VENTILATION In a sauna, the air should be changed about 6 times an hour. This can be achieved by making a vent opening (fresh air inlet) in the sauna wall directly below the heater. The air outlet must be lower than the upper benches, as far as possible from the heater and about two feet higher than the fresh air inlet vent, See Diagram 9.

It is recommended that ventilation openings meet the requirements of UL Specification 875. The minimum opening should be determined using one of the following formulas:

$$\text{For } R < 31, \quad V \geq 9.3$$

$$\text{For } R \geq 31, \quad V \geq 0.3R$$

where R = the floor area of the room in square feet and
 V = the minimum vent size in square inches

SECTION 12: MAINTENANCE

The sauna, like a bathroom, should be kept clean and odor free.

Towels or mats should always be used on benches and floor as perspiration otherwise penetrates the soft wood.

Air out the sauna often by keeping the door and vents open when the sauna is not in use. Saunas that are in daily use should be washed down at least once a week to keep them clean and the air fresh. Duckboard should be removed from the sauna, the sauna floor mopped and dried in a conventional manner, and the duckboard thoroughly scrubbed and dried before returning to the sauna room. The sauna heater should be wiped down occasionally with a damp cloth to remove lint and dust. The rocks should be removed once a year for cleaning and small or crumbled rocks replaced.

To clean and remove perspiration stains, use soap or detergent in warm water, best applied with a scrub brush. Badly soiled surfaces may require sanding. Sand paper wrapped around a wooden block works well.

Benches and supporting structure must be inspected annually for potential deterioration due to age, dry rot or abuse. Any boards with signs of deteriorations should be replaced immediately to avoid possible injury.

SECTION 13: TROUBLESHOOTING

For troubleshooting or service questions call 1-800-331-0349 and ask to speak with service.

WARNING